



Cool-Line AP

AP SERIES FEATURES

- Bar and Plate brazed aluminum core
- Competitive pricing and assembles from stock
- Patented flexible profile for long life
- Packaged system with pump and filter
- Cooling mediums include oil or water-glycol



MADE IN THE USA

AKGcoolers.com

1 (805) 484-0049

Sales@AKGcoolers.com

GLOBAL STANDARD COOLING SYSTEMS (AP SERIES)

OIL-TO-AIR COOLING SYSTEMS

PRODUCT INFORMATION

AKG AP Series, based on AKG Cool-Line Series, is a standard line of products from the market leader in high performance aluminum. AKG is best known for its world-wide presence, German engineering and extremely reliable product quality on the one hand and competitive prices on the other hand.

All of AKG's solutions have been developed with state-of-the-art technology, produced in compliance with the highest quality standards and are comprehensively tested in the company's own research and test facility.

The AKG Offline series consist of different offline cooler models to be used for cooling, filtration or lubrication circuits at low pressures in industrial or mobile applications.

FEATURES OF THE AP-SERIES

- High-performance cooling assemblies complete with an aluminum bar and plate cooler, fan, guard, and integrated pump/motor and optional filter.
- The heat is transferred from the oil medium to ambient air.
- Ideal for systems with varying flow rates or pressure spikes in return lines. Applications include cooling gearboxes, lube oil, hydraulic presses, CNC machining and injection molding presses.
- Suitable for ISO VG32 - ISO VG 320 and water glycol.
- Integrated cooling system with pump flows that range from 11.3 gpm - 18.7 gpm.

BENEFITS

- Highly flexible, ready to mount for offline cooling package.
- Requires minimal space and ready to be installed.
- Compact and robust design, field-tested in rugged real life conditions.
- Best heat transfer results for a given cooler size due to comprehensive research and development.
- All parts stocked for quick ship.

MATERIALS

- Cooler Core: Brazed Aluminum Bar and Plate
- Fan Guard, Shroud and Mounting: Steel
- Fan Blade: Aluminum Hub, Plastic Blades
- Motor: NEMA - TENV



GLOBAL STANDARD COOLING SYSTEMS (AP SERIES)

PERFORMANCE DATA

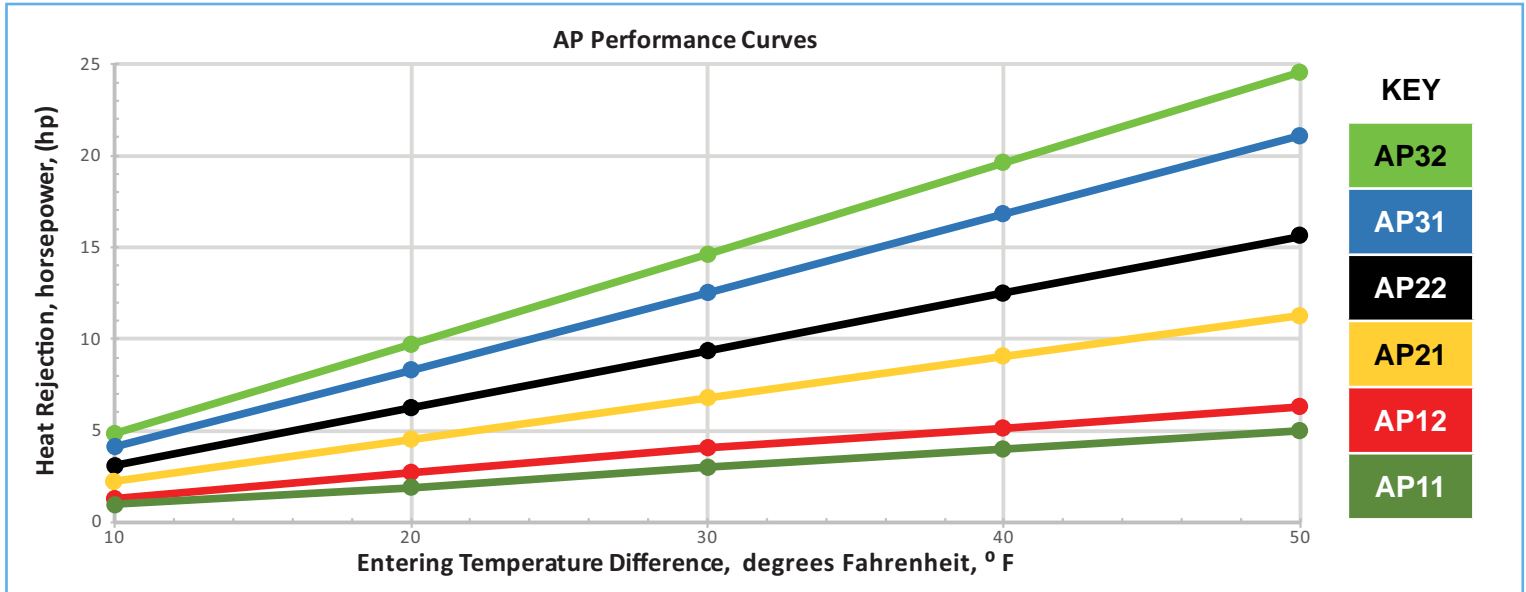

| Model | Displacement cu.in. (CC) | Flow gpm |
|-------|--------------------------|----------|
| AP11 | 1.46 (24) | 11.3 |
| AP12 | 2.50 (41) | 18.7 |
| AP21 | 1.46 (24) | 11.3 |
| AP22 | 2.50 (41) | 18.7 |
| AP31 | 1.46 (24) | 11.3 |
| AP32 | 2.50 (41) | 18.7 |

SELECTION PROCEEDURE

- STEP 1** Determine heat load. In most cases you can use 1/3 of the input horsepower of input HP.
- STEP 2** Determine Entering Temperature Difference (ETD)
 $ETD = \text{Entering oil temperature (°F)} - \text{Entering ambient air temperature (°F)}$. The entering oil temperature is generally the maximum desired systems oil temperature.
- STEP3** Select Model From Curve.

Listed performance curves are based on ISO VG 32 oil @ 85-PSI.

TECHNICAL DATA

Pump/Fan Motor Data

| Model Number | Displacement cu.in. (CC) | GPM Flow | Operating Pressure PSI (Bar) | Motor Hp | RPM | Motor voltage 60/50 Hz | HZ | Full Load Amps 208-230/460 | Approx. Sound Pressure SPL d(B)A @ 1-Meter | Volume (Gallons) |
|--------------|--------------------------|----------|------------------------------|----------|------|------------------------|----|----------------------------|--|------------------|
| AP11 | 1.46 (24) | 11.3 | 50 (3.4) | 2.0 | 1725 | 208-230/460 | 60 | 8.8-8.6/4.3 | 68 | 0.27 |
| AP12 | 2.5 (41) | 18.7 | | | | | | | | |
| AP21 | 1.46 (24) | 11.3 | 50 (3.4) | 2.0 | 1725 | 208-230/460 | 60 | 8.8-8.6/4.3 | 69 | 0.45 |
| AP22 | 2.5 (41) | 18.7 | | | | | | | | |
| AP31 | 1.46 (24) | 11.3 | 50 (3.4) | 3.0 | 1725 | 208-230/460 | 60 | 8.8-8.6/4.3 | 78 | 0.63 |
| AP32 | 2.5 (41) | 18.7 | | | | | | | | |

All data based at nominal speed

GLOBAL STANDARD COOLING SYSTEMS (AP SERIES)

DIMENSIONS & WEIGHT

| Model Number | A | B | C (Aprox.) | D | E | F | G | H | Weight (lb) |
|--------------|------|------|------------|-----|------|-------------------------------|------------------------------|-------------------------------|-------------|
| AP11/AP12 | 15.9 | 15.8 | 27 | 4.9 | 12.6 | #16 SAE 1 5/16-12 UN-2B | #20 SAE 1 5/8-12 UN-2B | #16 SAE 1 5/16-12 UN-2B | 145 |
| | | | | | | | | | 149 |
| AP21/AP22 | 19.6 | 21.6 | 28 | 5.3 | 15.9 | #20 SAE 1 5/8-12 UN-2B | #20 SAE 1 5/8-12 UN-2B | #16 SAE 1 5/16-12 UN-2B | 178 |
| | | | | | | | | | 183 |
| AP31/AP31 | 24.1 | 25.6 | 28.3 | 5.2 | 20.4 | #20 SAE 1 5/8-12 UN-2B | #20 SAE 1 5/8-12 UN-2B | #16 SAE 1 5/16-12 UN-2B | 214 |
| | | | | | | | | | 219 |

All dimensions in inches and for reference only. Subject to change without prior notice. *

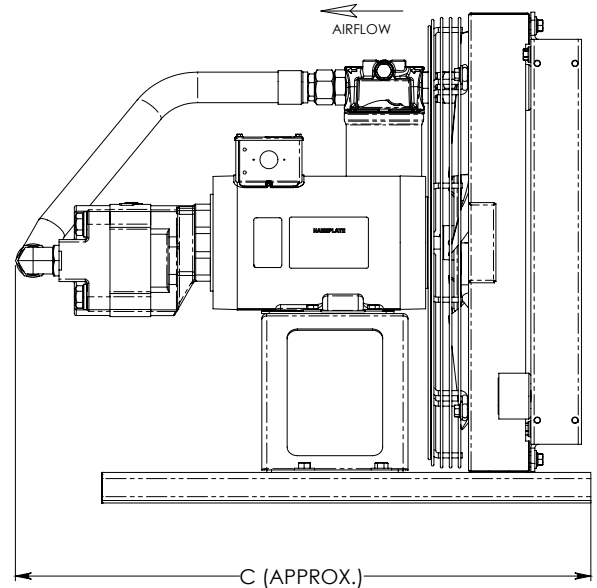
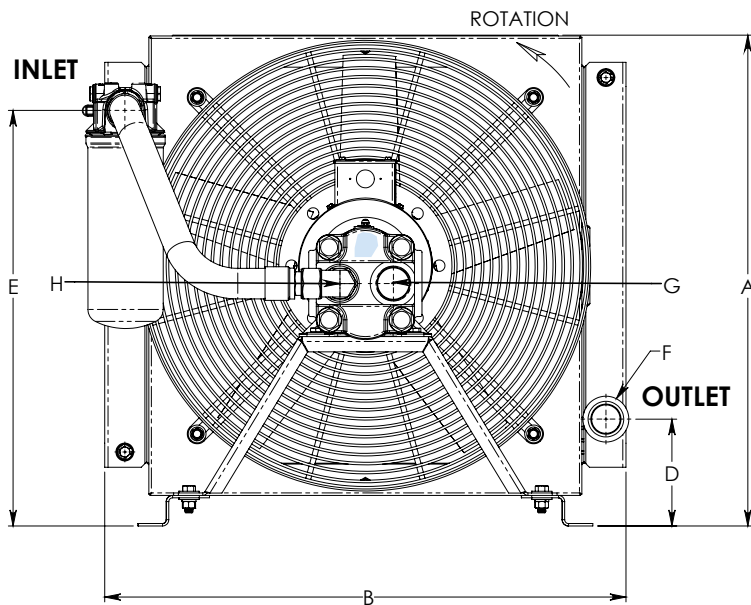

FILTER & PUMP SPECIFICATIONS

Filter Housing Materials

- Head - die cast aluminum
- Maximum working pressure: 500 - psi
- Flow Rating: 35 - gpm
- By-Pass Rating: 500 - psi
- Connections inlet / outlet: #20 SAE / #16 outlet
- Seal: Buna - N
- Filter rating: 150 - psid

Pump

- Pump maximum pressure: 2,500 - psi
- Viscosity range: Water Glycol 50/50 mixture
Oil ISO-VG32 - ISO VG 320
- Pump maximum speed: 2,400 - rpm
Minimum speed: 600 - rpm
- Displacement: 24cc & 41cc
- Left hand rotation **ONLY**
- Maximum fluid temperature: 170°F (76°C)
- SAE A mount - 2 bolt with SAE B shaft
- Suction: Flooded line not to exceed 20 - psi

GLOBAL STANDARD COOLING SYSTEMS (AP SERIES)

CARE INFORMATION

CORE ASSEMBLY/MOTOR

- AP coolers are designed for maximum oil pressure of 377-psi (25 Bar) and a maximum oil temperature of 250°F (121°C) without filter.
- The fan should not be cycled on/off.
- A source of unhindered fresh ambient air flow is needed for proper performance.
- All piping must be supported to prevent strain on cooler. Where excessive vibration may occur, flexible connectors are recommended.
- Installation should be completed by a certified electrician complying with all area codes.
- Be sure to provide proper fusing to prevent motor burn out.

MAINTENANCE

- In operation with heavy soiling, regular cleaning must be carried out. Be sure to disconnect the power supply and follow designated lock out procedures prior to service. Inspect for corrosion and clogged heat transfer surface.
- External cleaning can be done by either washing the core with a mild cleaner (compatible with aluminum) or compressed air. A power sprayer works well, the direction of stream shall be parallel to fins in order not to damage.
- Motor lubrication of motors 5-hp and below have sealed bearings and do not require lubrication.

FILTER

- Make sure that operating fluid is compatible with filter body, cartridge and seals.
- Spare parts installed must be in compliance of the design specifications provided in the operation manual.
- After opening the filter to change an element, check the conditions of the seals; replace if necessary.
- Recommend replace filter approximately every 3-months.

CHANGING THE FILTER

- Depressurize the system.
- Collect all oil and cartridge in proper container for disposal.
- Lubricate the filter element seal, insert the filter element into the filter housing and then insert the cartridge into the head spigot.
- Screw housing onto the head using proper tool. Do not apply excessive tightening torque.
- Start the machine to check for leaks.

PUMPS

- Piping connected to the pump **MUST** be independently supported to prevent strains on pump housings. Allow for expansion and contractions from pressure and temperature changes.
- Do not operate pump without liquid to avoid cavitation.
- Pump life is related to liquid cleanliness. Filters and suction strainers are to be installed to prevent contaminants into the pump.
- Operate only liquids approved for use with these pumps.

ORDERING INFORMATION

MODEL SIZE:

PUMP CODE:

FILTER CODE:

MODEL SIZE:

AP = Selected (AP11, AP12, AP21, AP22, AP31, AP32)

PUMP:

P = Includes Pump
X = No Pump

FILTER:

F = Filter Head, Spin-On Filter, 5 Micron Media, 50 psi Bypass, Visual Indicator, Hoses & Connectors
X = No Filter, No Hosing & No Connectors